



Ion Implanter Issues...

(and Solutions)

GSVIUG, May 2002

Tyson Grant

760.438.9090-phone
760.438.3923-fax
Sales@egraph.com

E/G Electro-Graph, Inc.
2365 Camino Vida Roble
Carlsbad, CA 92009 USA

ELECTROGRAPH®

Introduction

- In operating an implanter, there is a tremendous amount of cost incurred throughout all aspects of operation:
 - Expensive parts
 - Scheduled down-time (PM's)
 - Un-scheduled down-time (premature failures)
- There are a variety of solutions available from OEMs and second source suppliers to address many of these issues.

A Parts Perspective...

- Generally, parts for implanters are very expensive
 - This trend is due to exotic materials, tight tolerances, low production volumes, and special handling requirements.
 - Can't really improve on tolerances, production volumes, handling requirements.
- Cost savings can be made by focusing on materials utilization
 - Carefully choosing the optimal materials for each application
 - Using redesigned components for less expensive operation

Materials

As the cost of the raw materials and the time spent machining them are large factors in cost of parts for implanters, it is important to utilize materials effectively to save cost while improving performance.

- Graphite selection
 - Am I using the most cost effective grade for my application?
 - Erosion
 - Particles
 - Out-gassing
- Tungsten, Molybdenum, Tantalum selection
 - Can graphite substitute?
 - Can a different metal substitute?
 - Process
 - Structural

Graphite Selection

Typical Material Properties

	Standard Graphites					Post-Processed Graphites			Specialty Graphites
	2120-PT	CX-2305	DFP-3-2	SCF-2	Zee	Carbo 500	ACI****	Pyrograph	Carbograp 430
Particle Size (microns)	8	10	4	6	1		10		
Apparent Density (g/cc)	1.85	1.85	1.88	1.77	1.81	1.85	1.83	1.56	2.22
Flexural Strength (psi)	10,158	9,142	12,000	13,500	20,842	9,432	11,400	7,750	12000, 50000
Compressive Strength (psi)			20,000	25,000	37,258		26,300	14,200	15000, 25000
Tensile Strength* (psi)	7,111	6,400	8,500	9,500	26,080	6,600	8,300	9,940	1,000
Electrical Resistivity (micro-ohm*in)	630	354	600	960	1,211	590		790	1270, 1524000
Shore Hardness	68	60	74	91	113	75	85	66	103, 68
CTE (micro-in/in/C)	5.7	5.3	8.1	7.6	8.6	5.3	5.5	7.5	.6, 6.8
Thermal Conductivity (watts/m K)	81	95	95	60**		90	70		345, 1.73
Oxidation Threshold*** (deg C)			440	580		450			450
Air Flow @ 60 psi (cc/min)			1	50	12			0	0
Purity (% carbon)	99.9980%	99.9980%	99.9995%	99.9995%	99.9995%	99.9995%	99.9995%	99.9995%	99.9990%
Pyrolytic Carbon (approximate)								12% pick-up	
Graphite (approximate)			6% pick-up						
Impregnation Depth (in)						>.236	.04-.1	>.1	
Source	Carbone	Carbone	Poco	Poco	Poco	Carbone	Toyo Tanso	Poco	Carbone

* Estimated at 70% of flexural strength

** Estimated Values

*** Temperature that results in 1% weight loss in 24 hours.

**** Indicates values for raw, un-impregnated material

***** For Solid PG, many of the properties are anisotropic. The first number refers to the "a" direction, the second number to the "c" direction

"a" - along basal planes (across surface); "c" - through basal planes (through thickness)

There are a variety of graphite materials available for use in ion implantation. The chart above shows several of the materials that are currently in use in production and testing. In order to determine the best material for each application, extensive testing must be performed. This work has been and is being carried out by OEMs, graphite material manufacturers, second source suppliers, and customers.

760.438.9090-phone
760.438.3923-fax
Sales@egraph.com

E/G Electro-Graph, Inc.
2365 Camino Vida Roble
Carlsbad, CA 92009 USA

ELECTRO-GRAPH®

Graphite Selection

Some findings in graphite testing are contrary to long-held beliefs. In a paper published by Varian (IIT 1996, M. Mack et al), they found that graphite erosion was dominated by a mechanism of thermal stress, not sputtering.

Through redesigning their mass slit, Varian has been able to greatly reduce erosion to the graphite mass slit. In turn, they have also been able to greatly reduce the number of particles generated by this sub-assembly.

By better understanding the erosion mechanisms in each of the applications within an implanter, we can improve upon the designs and materials used.

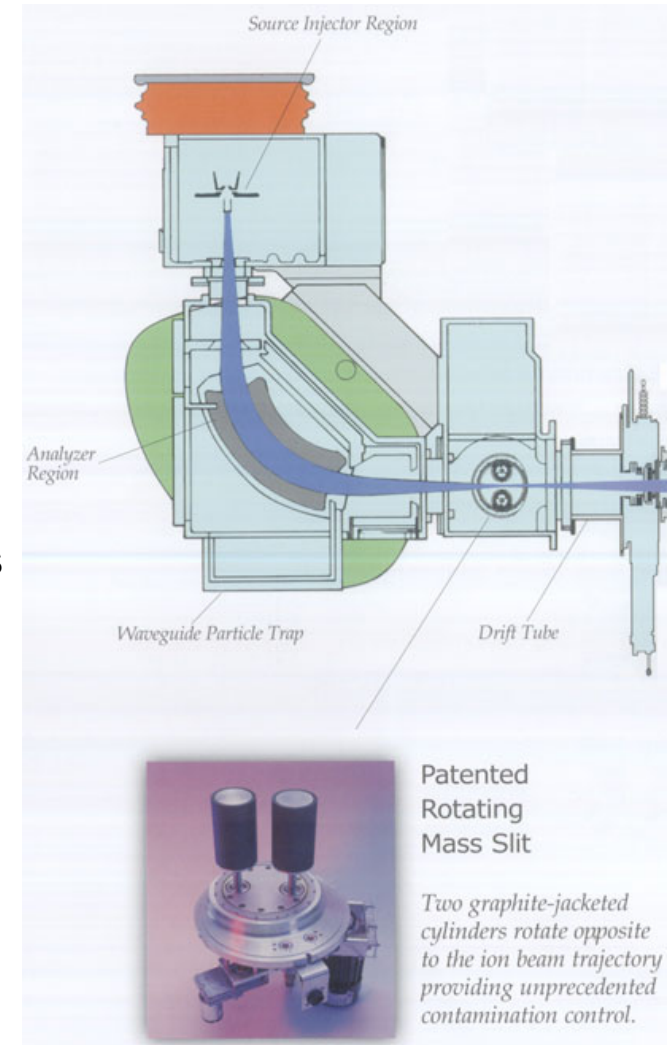

Source: Varian Semiconductor Equipment

760.438.9090-phone
760.438.3923-fax
Sales@egraph.com

E/G Electro-Graph, Inc.
2365 Camino Vida Roble
Carlsbad, CA 92009 USA

Metals Selection

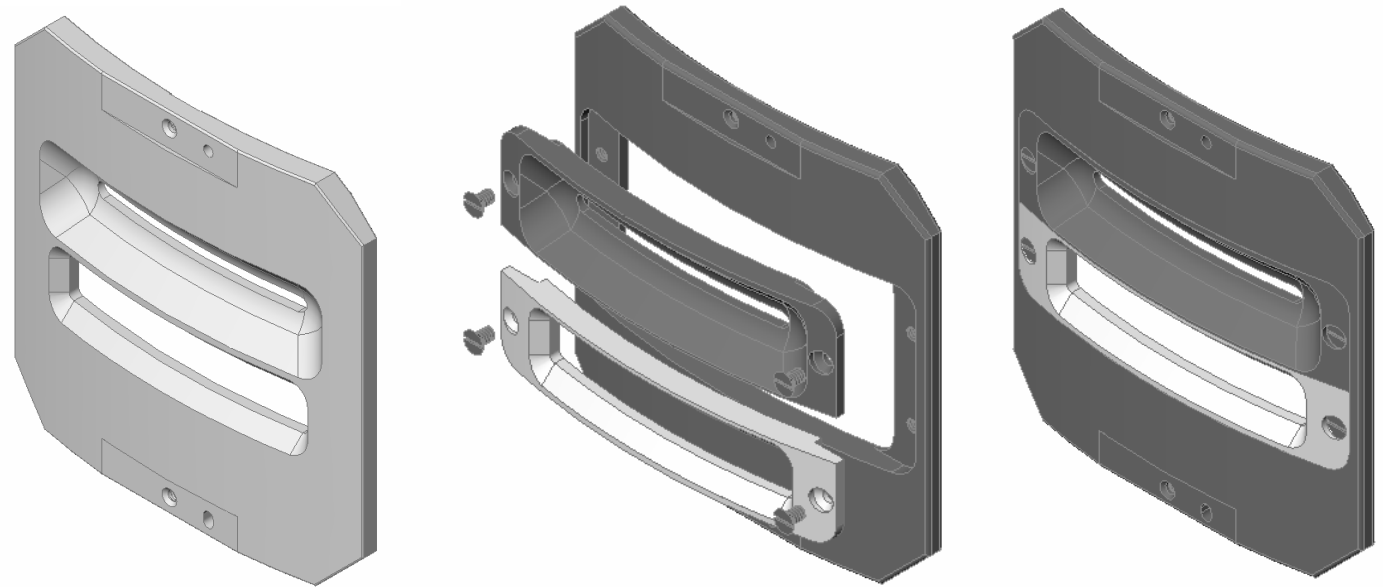

For some processes and applications, it is necessary to use refractory metals. However, by using expensive refractory metals only where necessary, we can reduce the costs associated with maintaining implanter performance. Existing tungsten, molybdenum, or tantalum parts can often be modified to sustain or improve performance at a fraction of the cost.

Redesigned Components

When redesigning components to reduce costs, there are a few things to consider:

- Maintain or improve performance
- Reduce cost of consumable components
- Improve serviceability

Maintain or Improve Performance

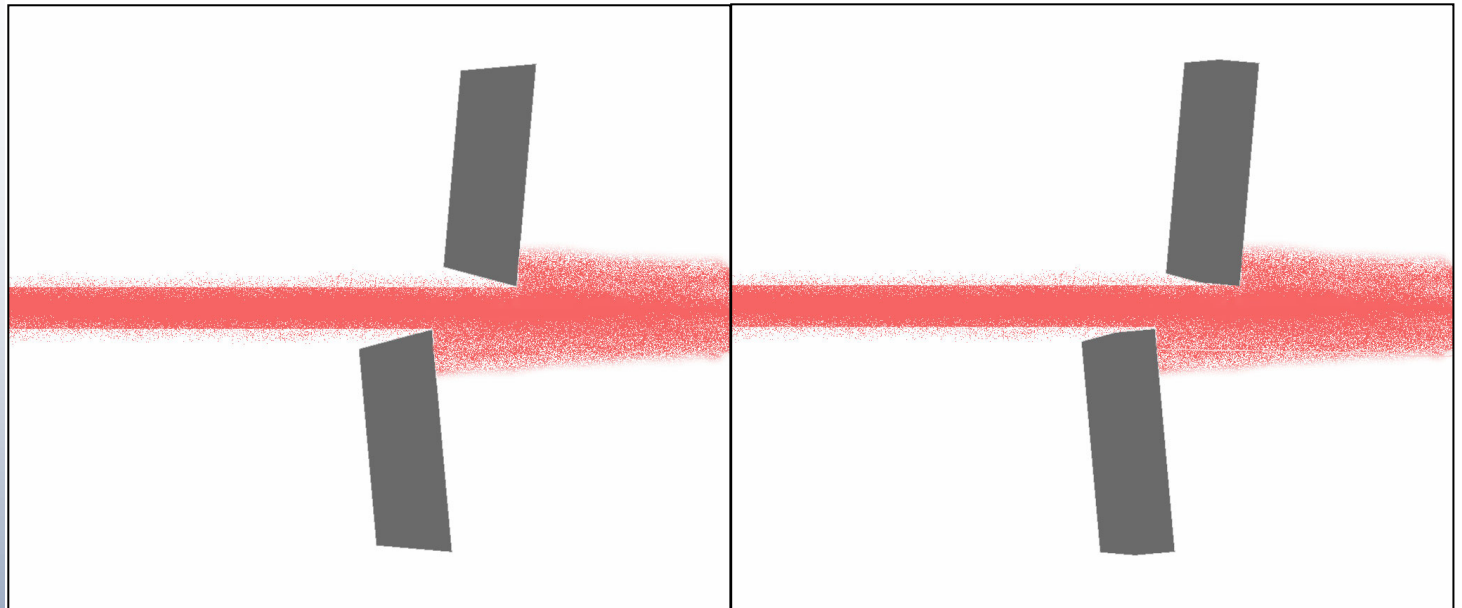

As you can see from the diagrams, there is much less material to erode on the standard design before the defining optics are lost. The edges that mask off the beam are relatively thin compared to the reinforced design. In contrast, it is very easy to see from the figure on the right how the reinforced vane design is physically much more resilient to erosion and beam strike.

Maintain or Improve Performance

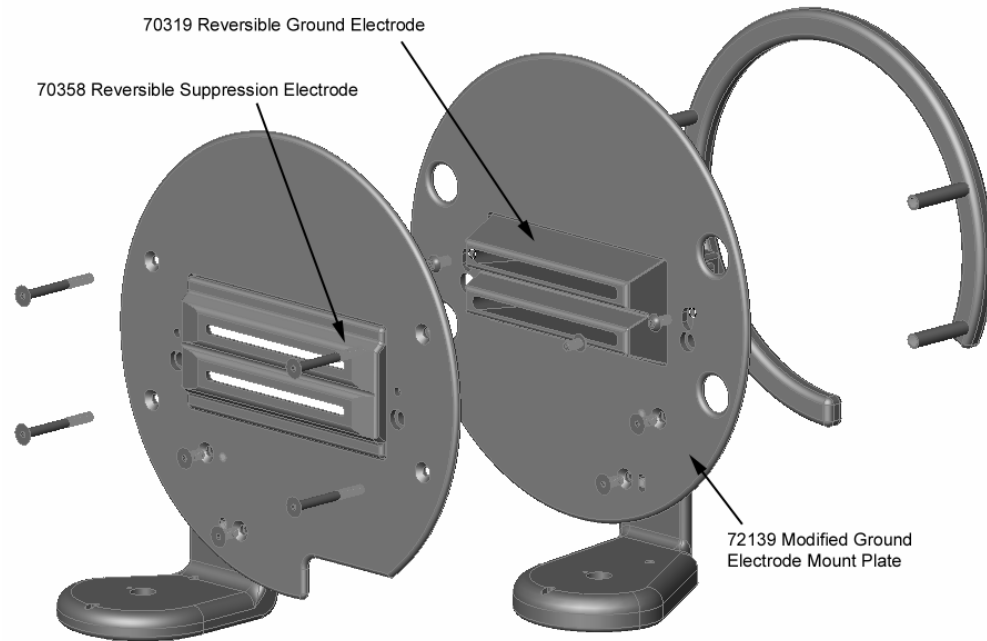

Through subtle changes in the ground electrode mounting plate, Electro-Graph has engineered reversible ground and suppressor electrodes. Each of these electrodes contain two, medium-high energy/mass beam apertures (typically +10mm alignment).

Our unique approach to the AMAT extractor allows users to double electrode life (where low energy boron aperture is not required).

Reduce Cost of Consumables

By making the arc slit into a 2-Piece design, Electro-Graph has given the customers the freedom to replace the beam defining portion of the arc slit at a substantial cost savings.

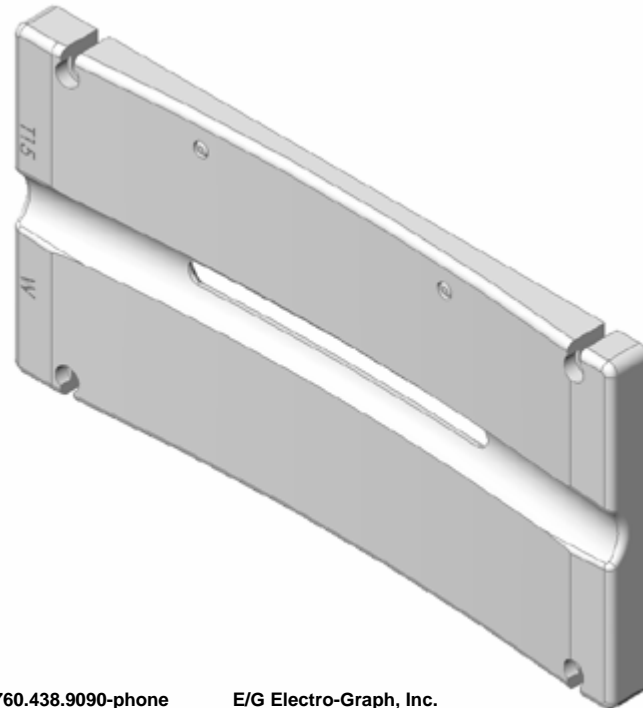
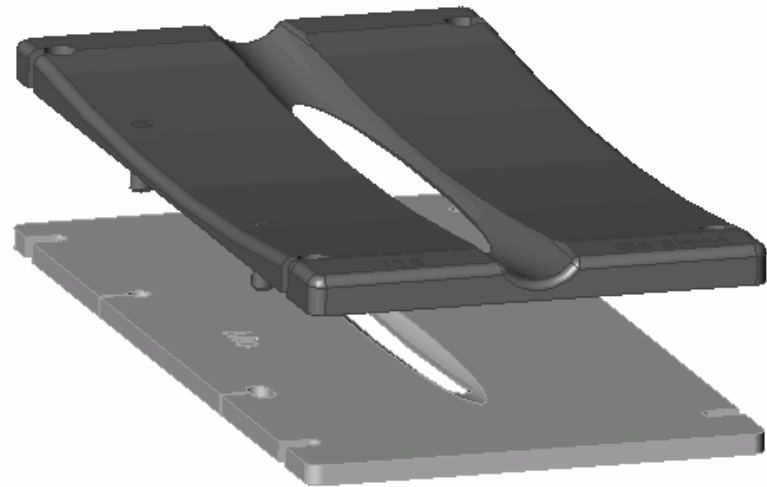

The real benefit will be found for those customers who want to maintain optimum beam optics. By using a 2 piece design, customers can replace the Tungsten or Moly portion of the arc slit while reusing the graphite piece numerous times before needing to replace it.

Reduce Cost of Consumables

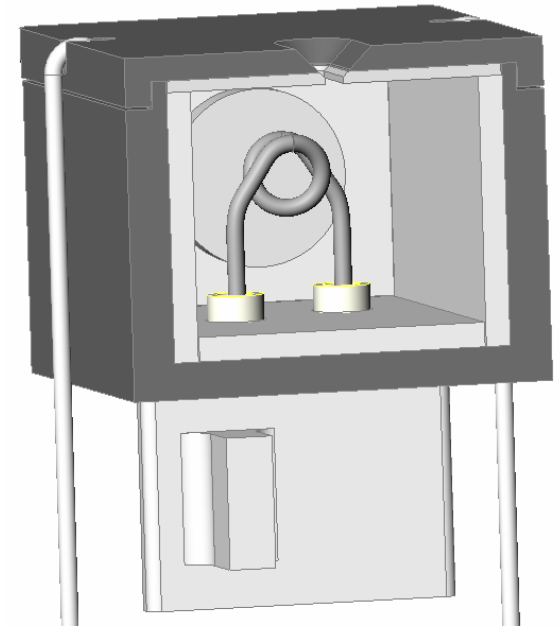
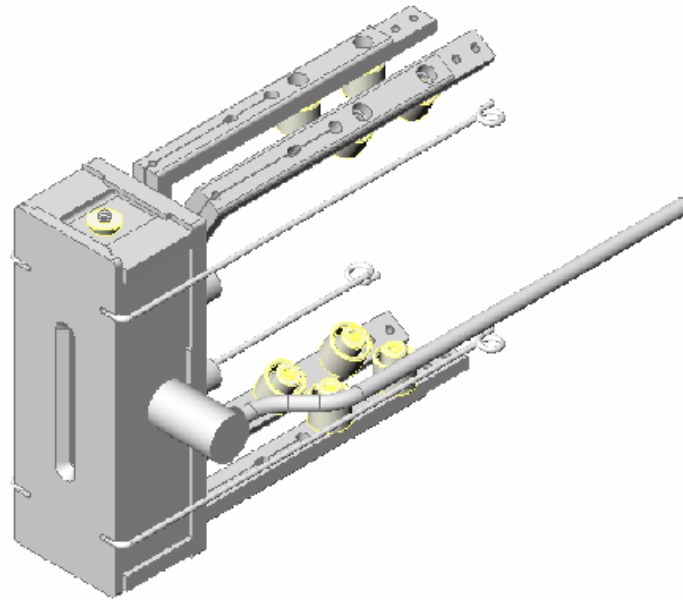

A monolithic, high purity, graphite arc chamber provides a low cost external shell for 1/8" thick rigid tungsten liners. The tungsten shim and graphite top plate reduces cost, provides standard source optics, and can be interchanged with the standard (full tungsten) top plate when used with modified side liners. A modified support plate and gas tube are required components of the solid VIISion ion source.

The primary benefit of the solid VIISion chamber lies in the users ability to reduce costs associated with full thickness, complex, solid tungsten sidewalls, base, and top without loss of process integrity or source performance.

760.438.9090-phone
760.438.3923-fax
Sales@egraph.com

E/G Electro-Graph, Inc.
2365 Camino Vida Roble
Carlsbad, CA 92009 USA

Improve Serviceability

The primary benefit of the modified beam dump design resides in the users ability to rebuild without removal of the assembly from the implanter. The outer ring is additionally replaceable for long-term operations. Rebuild of the standard Varian design (E17170014) requires a change out of the entire assembly and a relatively complex process to remove, insert, and re-qualify a new center piece. Comparison of individual rebuild costs, losses, related system downtime, and OEM replacement cost provide immediate COO benefits.

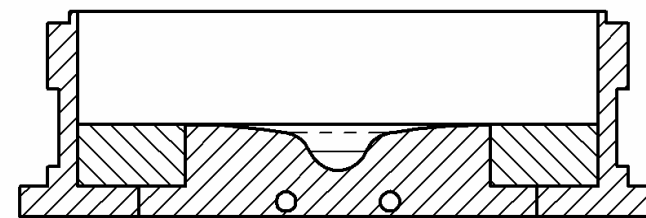

SECTION A-A

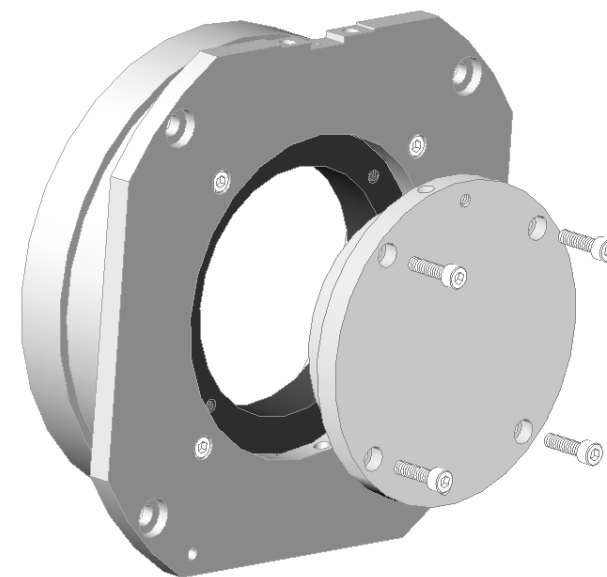

Improve Serviceability

The “No Hole Repellers” supplied by Electro-Graph are Type 1 ($\varnothing.142$) repeller upgrades designed to provide improved performance and reduced COO, while reducing the number of parts required for assembly. By combining the repeller and repeller stud, the “No Hole” design allows for a quicker, more robust, repeller set-up. Performance gains are achieved by eliminating the starting point for erosion with added material, thus extending life.

No Hole Repeller Set-up

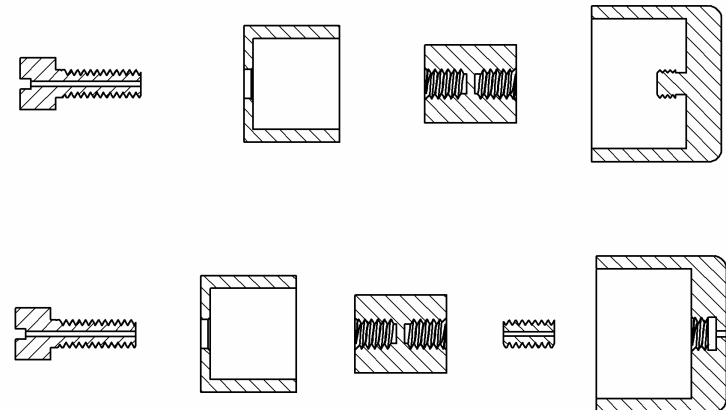

Standard Repeller Set-up

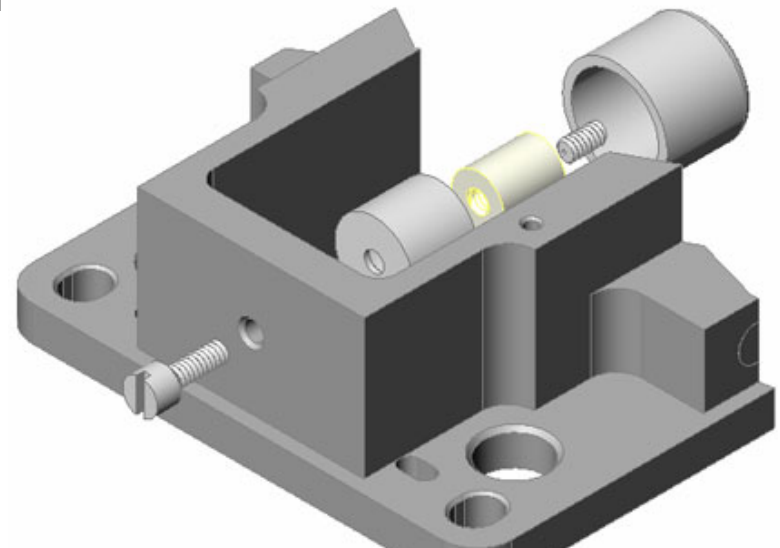

ELECTRO-GRAPH®

Improve PM Cycles

By increasing the amount of time between PM services, we can also increase up-time and generally reduce costs.

Typically, PM cycles are determined by the performance of one, or a few, parts. Improve those parts to get extended PM cycles.

Improve PM Cycles

The ELS2 cathode assembly is a bolt on hardware & electrical upgrade for Axcelis GSD implanters and is configurable for both H.E. and E2, ELS type ion sources. The design takes advantage of four incremental improvements to source life and assembly.

- The filament coil diameter has been increased to .040" from .034". Because of this increase in coil cross-section, a 9-volt Zener diode replacement is required to handle the increased filament current.
- A thicker tungsten slug (cathode button) is employed to reduce cathode burn thru and extend cathode life.
- Reliable, self-clamping, filament clamps are used in conjunction with a straight leg filament to provide consistent assembly and improve filament positioning.
- A redesigned cathode insulator extends the coating path length and provides positive, consistent, alignment for the newly designed filament clamps.

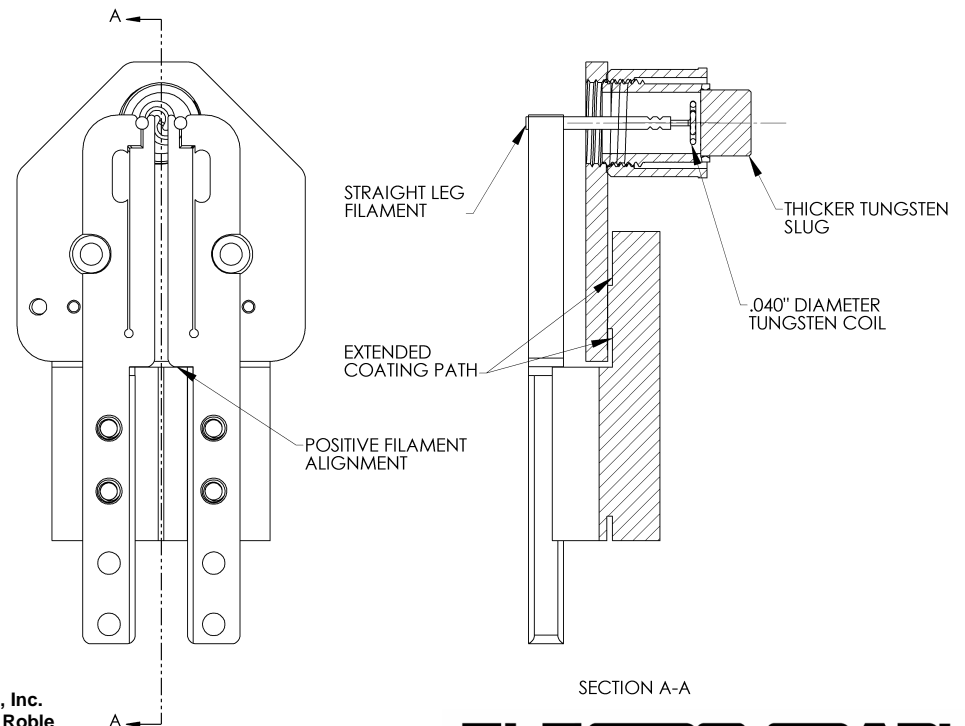

760.438.9090-phone
760.438.3923-fax
Sales@egraph.com

E/G Electro-Graph, Inc.
2365 Camino Vida Roble
Carlsbad, CA 92009 USA

Improve PM Cycles

Standard Insulator

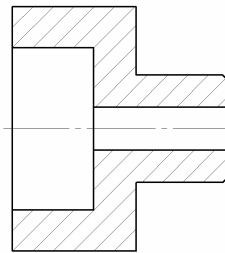
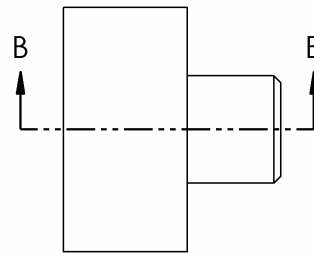

Modified Insulator

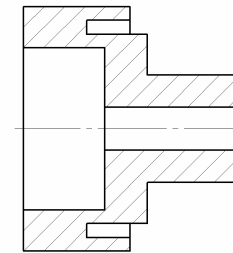
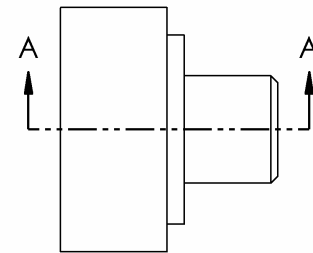

Electro-Graph currently offers an upgrade to the standard Bias Aperture Insulator, OEM#17174410, offered by Axcelis. By incorporating a deep groove and second shelf on the insulator, coating related failures are reduced substantially. Vast improvements on part life ranging from 3 to 10x have been observed with this new design.

760.438.9090-phone
760.438.3923-fax
Sales@egraph.com

E/G Electro-Graph, Inc.
2365 Camino Vida Roble
Carlsbad, CA 92009 USA

Reduce Premature Failures

In addition to increasing the time between PM services, we also need to ensure that the implanter goes down for unexpected service less frequently.

Strategies for reducing premature failures

- Consistency
 - Gauging
- Testing
 - Krytek
- Improved designs

Reduce Premature Failures

Modified Design

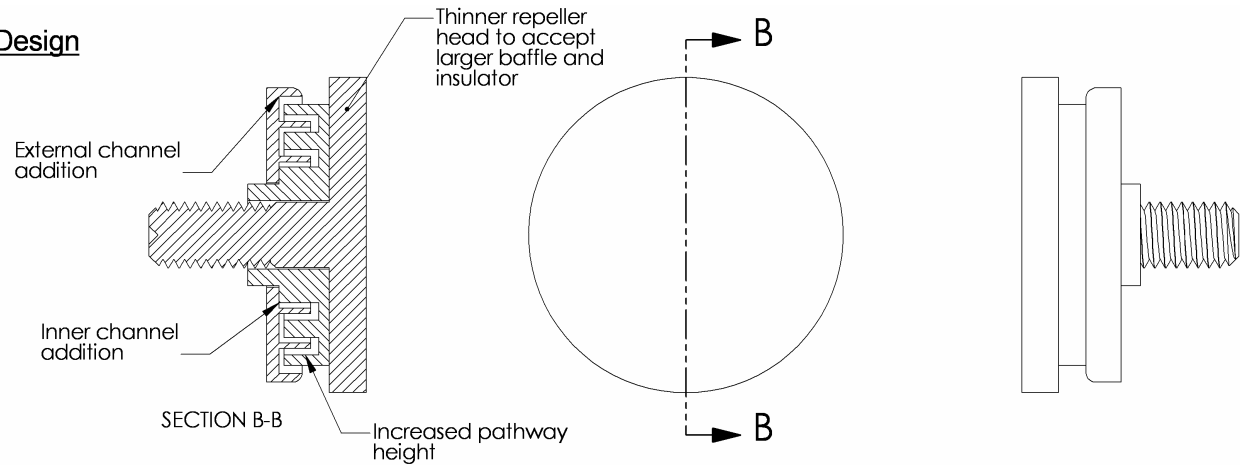

Standard Design

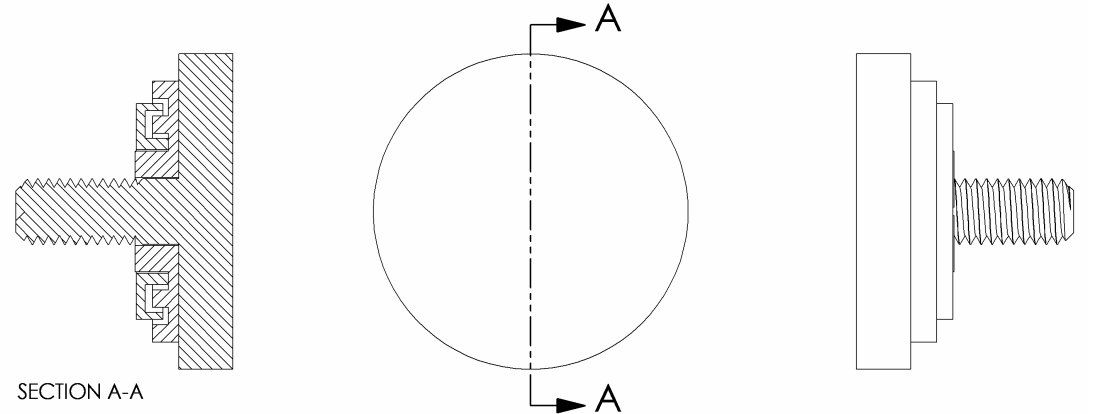

This repeller assembly modification addresses coating failure issues by extending the coating pathway. Not all processes see coating-related problems as the primary failure, but certain applications, such as Antimony, may benefit from increased surface area in the insulator/baffle configuration and a decrease in line-of-sight effect. If your primary failure is due to flaking issues or other non-coating related issues, this design may not provide increased benefits since its enhancement is based on an extended coating pathway.

760.438.9090-phone
760.438.3923-fax
Sales@egraph.com

E/G Electro-Graph, Inc.
2365 Camino Vida Roble
Carlsbad, CA 92009 USA

Reduce Premature Failures

Two styles of filament clamp are available for use with the ELS2 cathode assembly. Due to its small pivot point, customers have claimed the 17287880 is prone to breakage when installing the filament. Typically breakage occurs when the clamp is opened too far by over-rotating the filament screw. Electro-Graph has remedied this problem by increasing the size and moving the location of the pivot hole, and removing the filament screw hole. Another benefit gained through the redesigned filament clamp is the added galling control. By using the disposable nut plate, the filament clamp is free from galling to the screw. If the screw does gall, the plate can be broken and replaced.

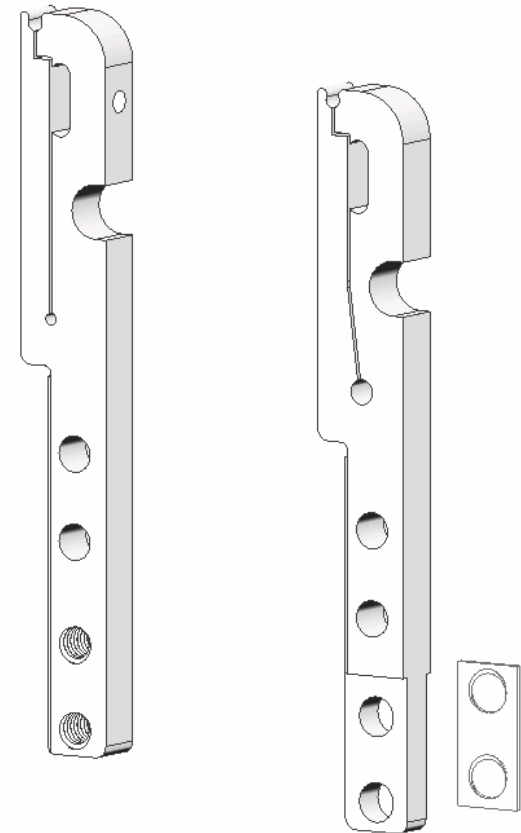

Conclusion

- There are a wide variety of options available to maximize implanter performance while reducing costs:
 - Carefully select appropriate materials for each application
 - Minimize utilization of expensive materials
 - Redesigned components for improved performance
 - Reduce down-time
 - Improved serviceability
 - Longer PM cycles
 - Reduced premature failures