

Productivity Plus

Option / Upgrade

E220 / E500 Series Implanter

July 2003

Productivity Plus Value Statement



- ❑ The fastest and most cost effective way to add capacity to your E-series medium current implanter install base without:
 - Purchasing additional implanters
 - Sacrificing fab space

- ❑ Hardware installation time is only 24 hours plus fab re-qualification

Presentation Agenda



- Overview
- Key Benefits
- Performance Comparison
- Beta Data
- Key Features
- Hardware Images
- Performance Charting
- CoO Advantage
- Availability / Price / Installation
- Prerequisites

Overview



Productivity Plus

- High throughput package
 - Option for new tools
 - Upgrade for installed tools
 - Hardware and software

- Applies to all installed E220 and E500 Series Implanters
 - 150mm and 200mm electrostatic-clamp
 - Planned capability for mechanical clamp

Key Benefits



- Throughput Increase
 - All E Series: Maximum throughput to = $250 \pm 3\%$ wph
 - Eliminates throughput loss due to cassette exchange time
- Scalable: Accommodates incremental capacity increases
- No increase in floor space
- Improved CoO
 - Reduced consumable consumption on a per wafer basis
- EHP_i Benefits Carried Forward
 - V12 Effective Throughput multitasking capacity
 - Redundant/independent operation of each side
 - EHP_i wafer breakage specification 1:40,000
 - No change in process or maintenance specifications

Comparative Performance



Throughput Matrix							
MODE	200mm		E2E5	E2E5HP	E2E5EHP	E2E5EHPi	Any E2E5 with Productivity Plus
A	Simultaneous	6 Scan	190	190	200	210	210
B	Dual Load Lock Single Arm	10 Scan	170	170		170	170
C	Alternating Load Lock Single Arm	6 Scan				144	
D	Single Load Lock Single Arm	6 Scan				124	
E	Super Shuffle	6 Scan	<189	<189	<189	<189	<189
F	Productivity Plus Single Load Lock Dual Arm	6 Scan	189	189	189	189	189
G	Productivity Plus Alternating Load Lock Dual Arm	6 Scan	250 + 3%	250 + 3%	250 + 3%	250 + 3%	250 + 3%
% Throughput improvement (Mode "G" over "A")			31.6%	31.6%	25.0%	19.0%	19.0%

*This matrix is a mechanical throughput matrix and does not account for all real production items i.e. Beam Interval Check, Post Implant Orient etc...

** Super Shuffle Mode is not improved by the introduction of Productivity Plus Hardware

	Published Specification
	Unpublished Specification
	Not Applicable
	Planned Capability
	Undefined

Beta Site Results



Comparison: 6 E-Series VSEA Implanters, one with Productivity Plus

JUNE 1-30, 2003							
	<u>RUN</u>	<u>IDLE</u>	<u>PM</u>	<u>UDOWN</u>	<u>Uptime</u>	<u>Wafers</u>	<u>Wafers Per Hour</u>
E2-EHP 037431	90.05%	6.40%	1.07%	0.43%	96.81%	72826	112.3
E2-EHP 037434	83.61%	6.13%	4.07%	0.00%	89.74%	68693	114.1
E2-EHP 037436	86.33%	6.90%	1.03%	1.55%	93.24%	76911	123.7
E2-EHP 037477	89.72%	7.55%	1.59%	0.32%	97.27%	79269	122.7
E5-EHPi 193645	89.82%	2.24%	2.40%	0.05%	92.06%	104012	160.8
E5-EHPi 193819	86.08%	10.56%	0.28%	0.22%	96.64%	83026	134.0
	87.60%	6.63%	1.74%	0.43%	94.29%	76145	128.1
Average performance advantage over equally equipt EHPi						25.3%	
Average over all performance advantage						36.6%	

Beta Site Results

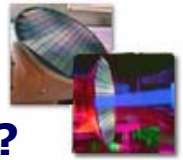

Why is the actual benefit greater than the mechanical improvement?

Mechanical Throughput Matrix						
MODE	200mm E-Clamp	E2E5	E2E5HP	E2E5EHP	E2E5EHPi	Any E2E5 with Productivity Plus
Standard Dual Load Lock Single Arm	6 Scan	190	190	200	210	210
Productivity Plus Alternating Load Lock Dual Arm	6 Scan	250± 3%	250± 3%	250± 3%	250± 3%	250± 3%
% Mechanical Throughput improvement		31.6%	31.6%	25.0%	19.0%	19.0%

	<u>RUN</u>	<u>IDLE</u>	<u>PM</u>	<u>UDOWN</u>	<u>Uptime</u>	<u>Wafers</u>	<u>Wafers Per Hour</u>
E2-EHP 037431	90.05%	6.40%	1.07%	0.43%	96.81%	72826	112.3
E2-EHP 037434	83.61%	6.13%	4.07%	0.00%	89.74%	68693	114.1
E2-EHP 037436	86.33%	6.90%	1.03%	1.55%	93.24%	76911	123.7
E2-EHP 037477	89.72%	7.55%	1.59%	0.32%	97.27%	79269	122.7
E5-EHPi 193645	89.82%	2.24%	2.40%	0.05%	92.06%	104012	160.8
E5-EHPi 193819	86.08%	10.56%	0.28%	0.22%	96.64%	83026	134.0
	87.60%	6.63%	1.74%	0.43%	94.29%	76145	128.1
Average performance advantage over equally equipped EHPi						25.3%	
Average over all performance advantage						36.6%	

Answer: Alternate Load Lock Processing



- Vacuum Independent load locks:
 - Convert previously lost "idle time" into "production time"
 - Vent and Beam Tuning now occur simultaneously
 - Operators now have ~3.0 minutes to perform cassette exchange without interrupting production
 - Non-Productivity Plus tools loose vent, cassette exchange and pump time to "Idle Time" (~5% of total time)

Comparison: Productivity Plus to Control Tool



4,247 More Wafers Processed in 5 Days with Productivity Plus

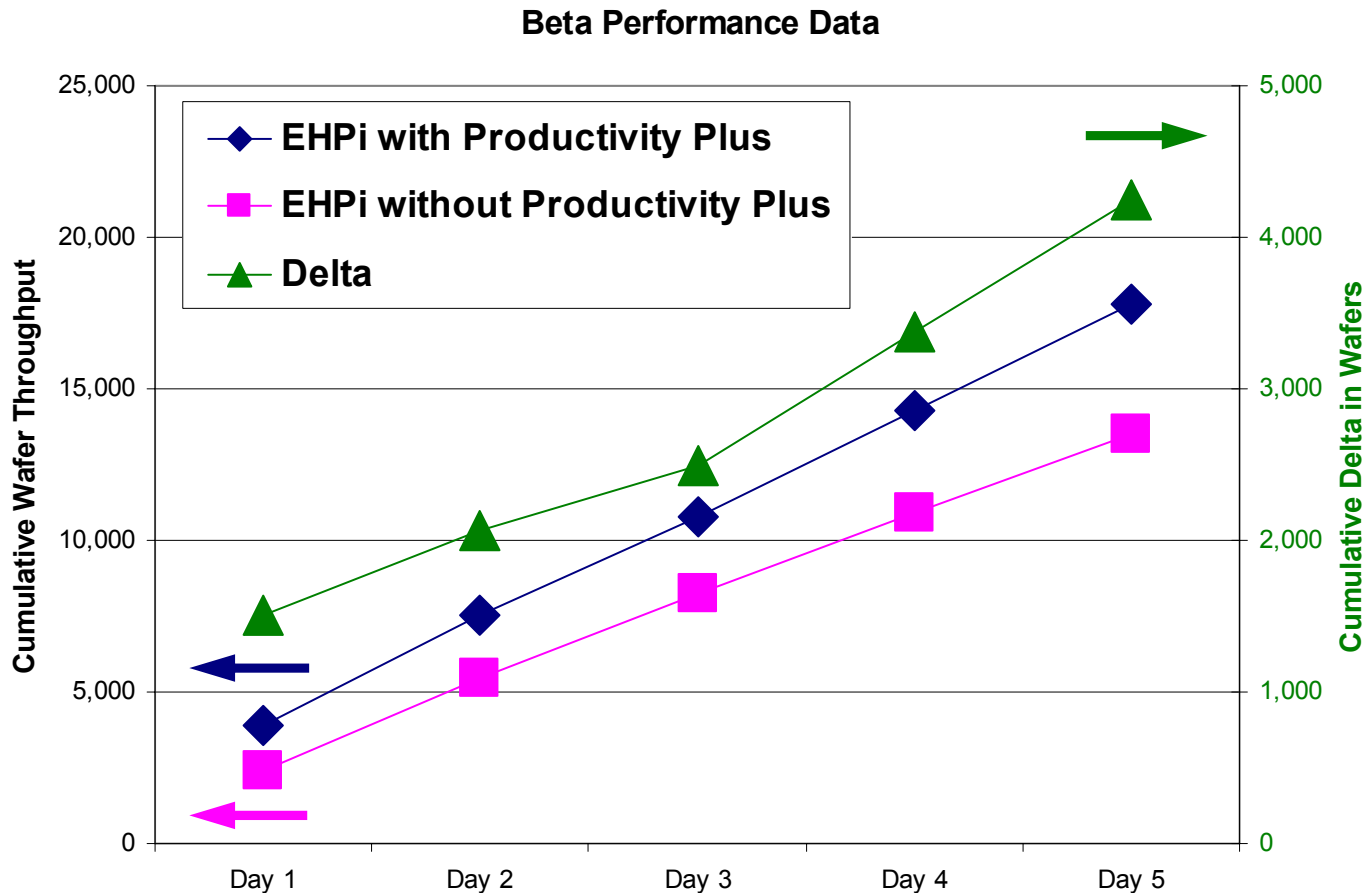



Key Features

- Alternate Load Lock Processing
 - Vacuum Independent Load Locks (VIL) save on vent, cassette exchange, and pump time with successive batches using the same recipe

Left load lock

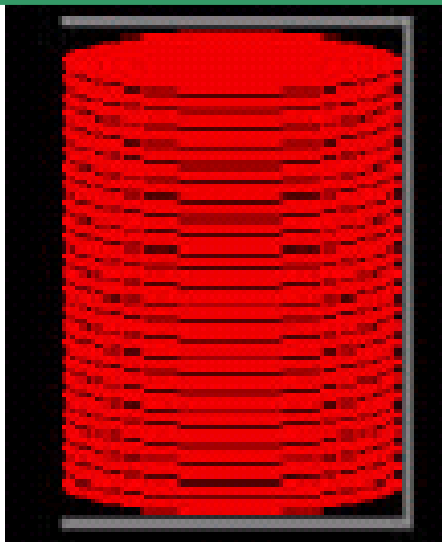

Pump
Implant
Vent
Cass.
Exchange

Right load lock

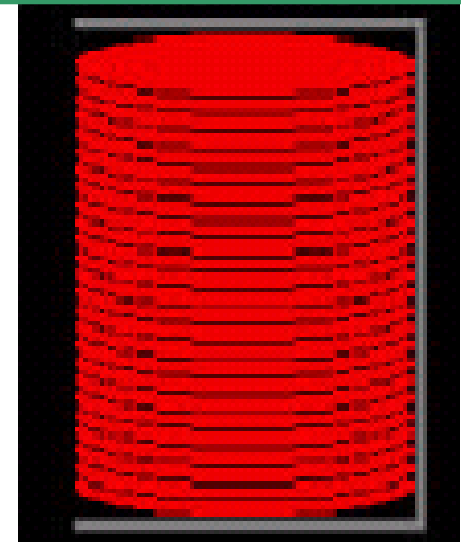

Pump
Implant
Vent
Cass.
Exchange

Constant Recipe: Successive Cassettes

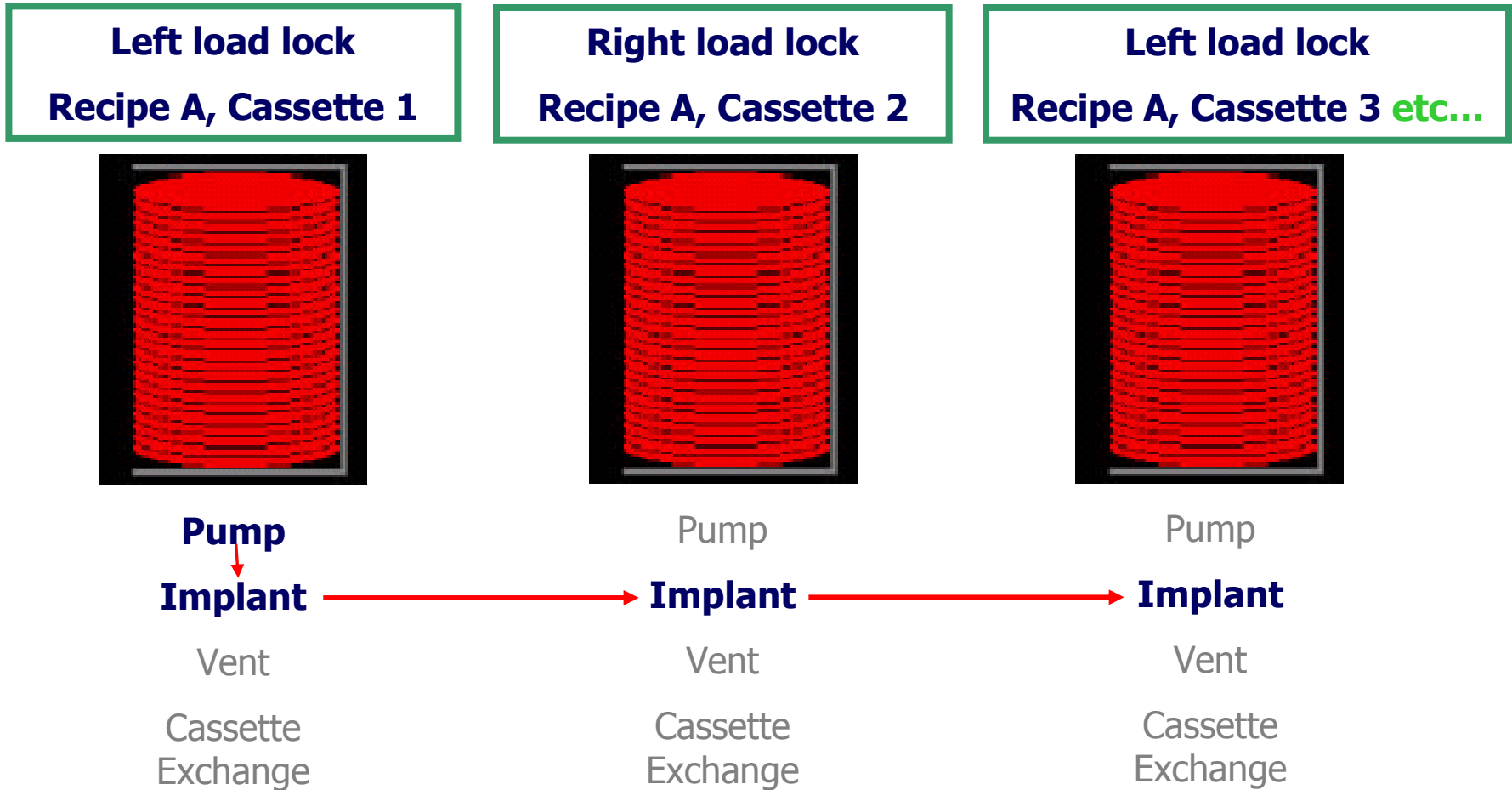

- Grey = Background Events

Key Features



- Additional right and left side wafer handling components:
 - Wafer handler pick, pick arm & alignment fixtures
 - Wafer handler drive assembly
 - Wafer present sensor
- New Wafer Handling Sequence (Patent Pending)
- Repackaged HW to accommodate additional components:
 - Wafer handler covers, pick and pick arm
 - Infrared orienter (sensing apparatus and pedestal only)
 - Break actuator (detent only)
- E-Clamp compatible
- Wafer motion handling speed is not increased

Key Features



- System software Version 13
 - Optimized wafer handling functions
 - Orient signal filtering, Bi-directional orienter motion
 - New user screens to support new hardware
- High reliability hardware components
 - Steel drive belts, Ferrofluidic seals
 - 1 Million wafers cycled
 - Components: 5 Million cycles / 75% confidence of 38 months MTBF
- EHP_i / Effective Throughput benefits carried forward
 - Simultaneous beam tuning with load lock pump and vent
 - Chained implant functionality
 - Recipe queuing - Preload 5 jobs via host or local control

Productivity Plus Hardware

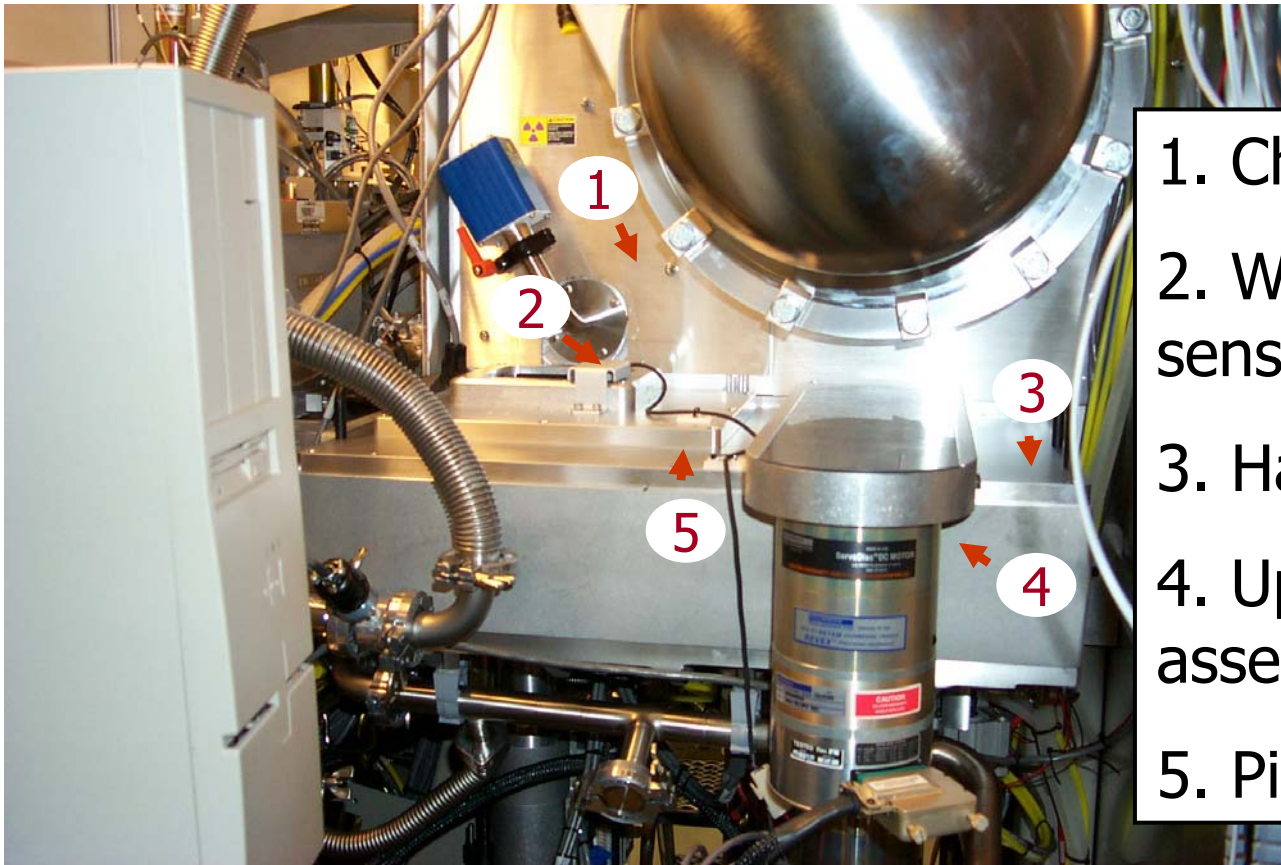

1. Chamber cover
2. Wafer present sensor
3. Handler bed cover
4. Upper arm drive assembly
5. Pick access cover

Productivity Plus Hardware



Servo Chassis:
Right Controller
Upper & Lower Arm
Left Controller
Upper & Lower Arm

**Handler cover with drive
assembly, pick, pick arm
(and wafer present sensor -
far side)**

Productivity Plus Hardware

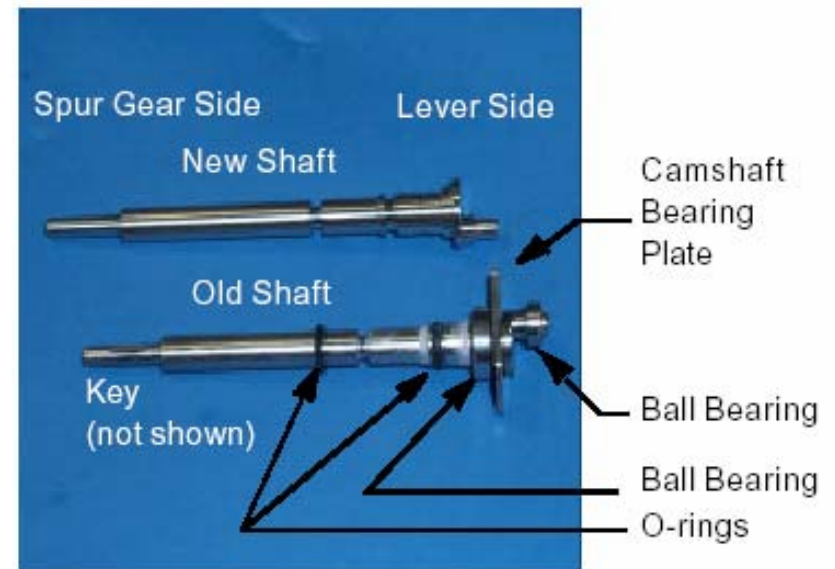

Additional new hardware includes modified roplat components to lengthen the pins stroke

Productivity Plus in Action



Pick Arm Function Summary

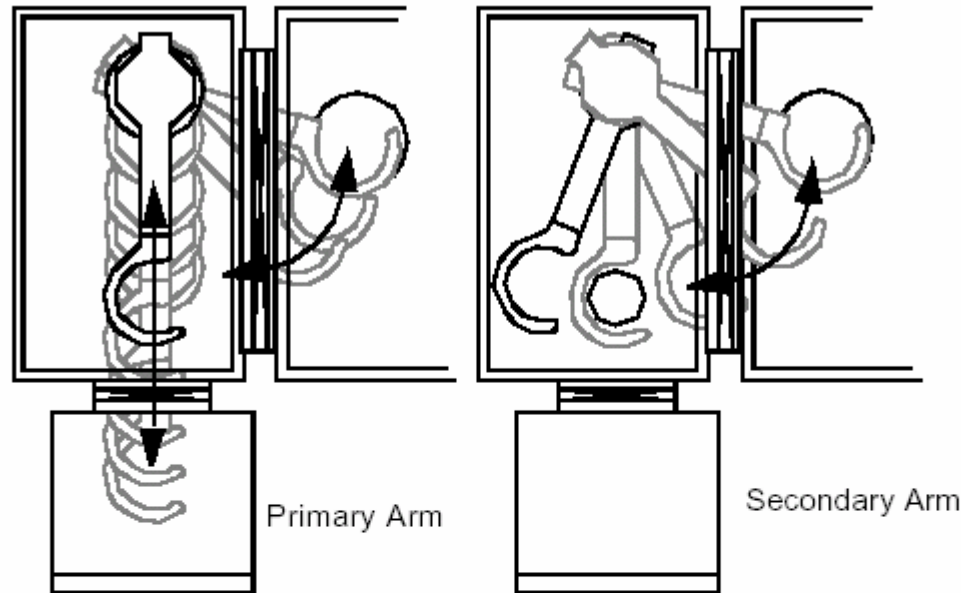

Pick Arm Movement Summary

Pick Arm	Location	Function	Movement	Restrictions
Primary	Lower handler	Transfers wafers to/from elevator Delivers wafers to orienter pedestal Removes wafer from platen	Rotates into target chamber Linear movement into elevator	Does not deliver wafers to platen
Secondary	Upper handler	Idles at edge of chamber Picks wafers off of orienter Delivers wafers to platen	Rotates into target chamber	Does not enter the elevator

Performance Charting



Calculated Productivity Plus Throughput Compared to Two-Load lock EHPi Operation

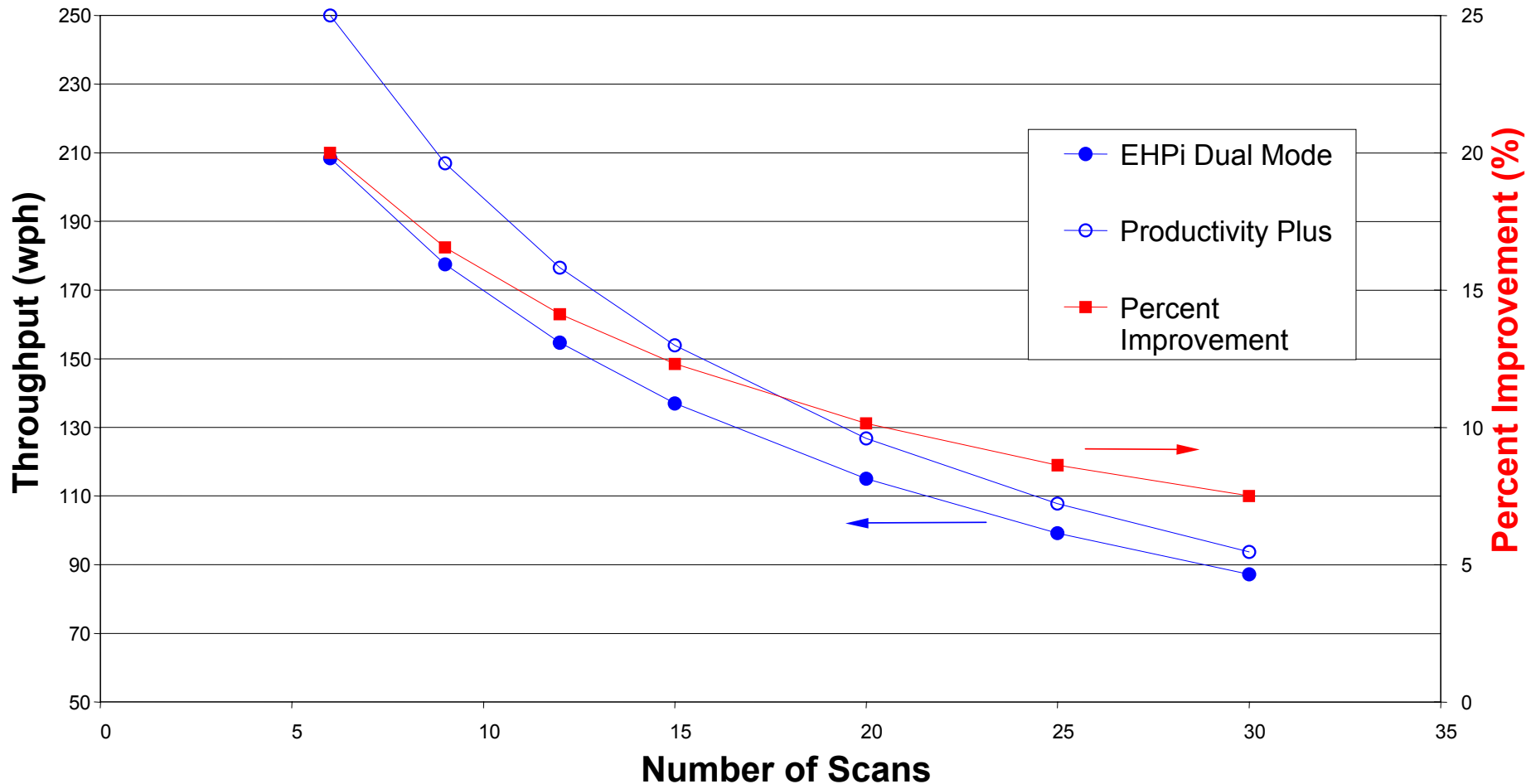

Performance Charting



Calculated Productivity Plus Throughput Compared to Alternating Single Load Lock EHPi Operation

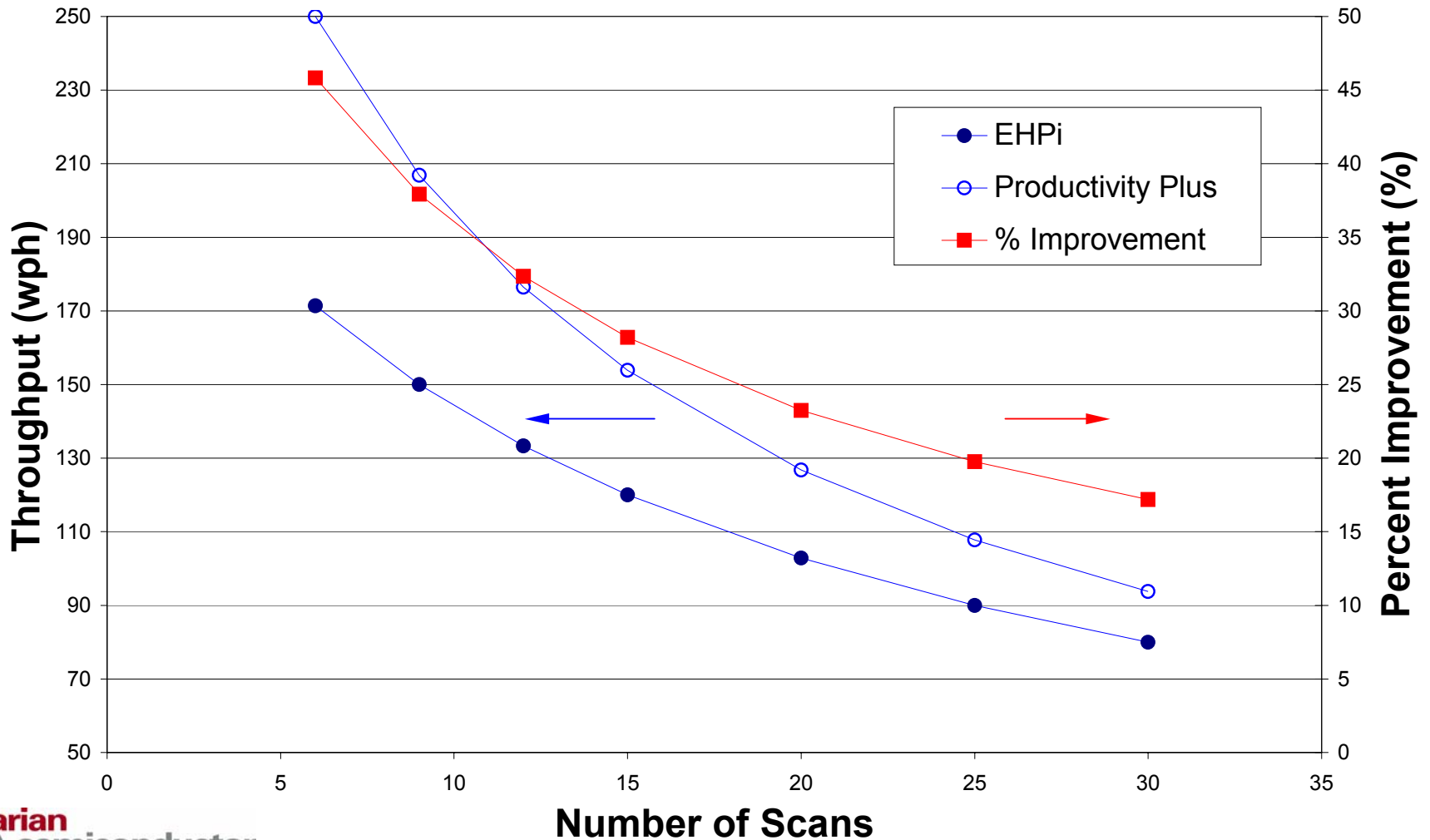

Performance Charting



Calculated Throughput Chart

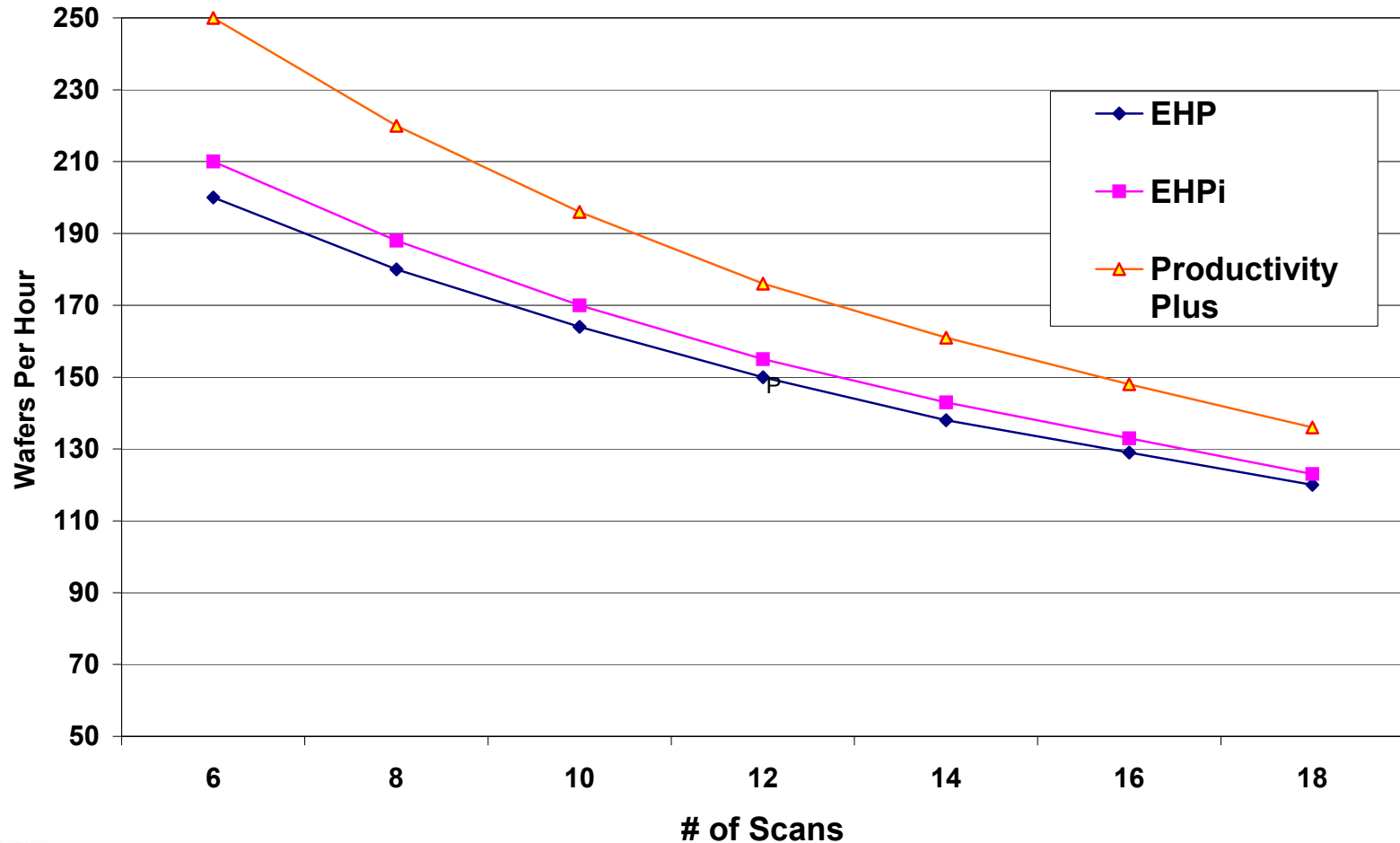

Improved CoO



- No increase in floor space
- Increased beam utilization
 - Reduced consumable use on a per wafer basis
 - Source consumables
 - Gas bottle consumption
 - Beam-line consumables
 - Maintenance labor
- Higher Effective Throughput
 - More wafers through the tool

Availability / Price



■ Availability

- ❑ 1st Beta shipment - April, 2003
- ❑ 1st order acceptance - June, 2003
- ❑ 1st Upgrade deliveries - 12 to 16 weeks ARO
- ❑ 1st production tool delivery - contact Tactical Marketing

■ Price

- ❑ Contact your local Service Office

Upgrade Prerequisites



***All systems require: Version 13 software and HOST programming modifications to permit Alternate Load Lock processing**

General configuration table

Required Prerequisites	E220/E500	E220HP/E500HP	E220EHP/E500EHP	E220EHPi/E500EHPi
IIS/TVL Traveling Faraday	N	S	S	S
Cassette Presence	N	S	S	S
Infrared Orienter	N	N	S	S
Load Lock Door Sensors	N	N	O	O
Cassette Pivot Sensors	N	N	O	O
Wafer Position Detect (LL)	N	N	N	S
Wafer Handler Position Detect	N	N	N	S
400MHz Control CPU	N	N	N	O
Latest Release Roplat Drive	N	N	N	S

Non-Standard
Standard Equipment
Option at the time of original build
Standard Late Cut-in

Installation



- Upgrade Installation
 - Pre-qualification: 4 hours
 - Hardware installation: 2 people, 2 shifts (48 labor hours)
 - SW must be previously installed and qualified
 - Enable Alternate Load Lock processing
 - VSEA re-qualification: 1 person, 2 shifts (24 labor hours)
 - includes 24hrs continuous: 2 shift marathon
 - Customer re-qualification - TBD

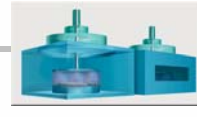
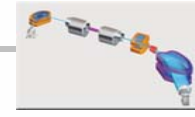
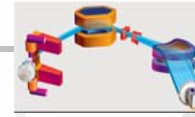
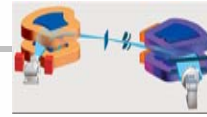

Supplemental Information

New Wafer Handler Chronograph and
Sequence for Productivity Plus

Chronograph Tutorial



- The following slide graphically illustrates the handling steps and timing for the new wafer handling sequence.
- Use the “New 16 Step Wafer Handling Sequence” slides to narrate the graphical slide.
- First understand the red and blue graphs by reading the red and blue legend for each mechanical component represented

ZOOM AREA

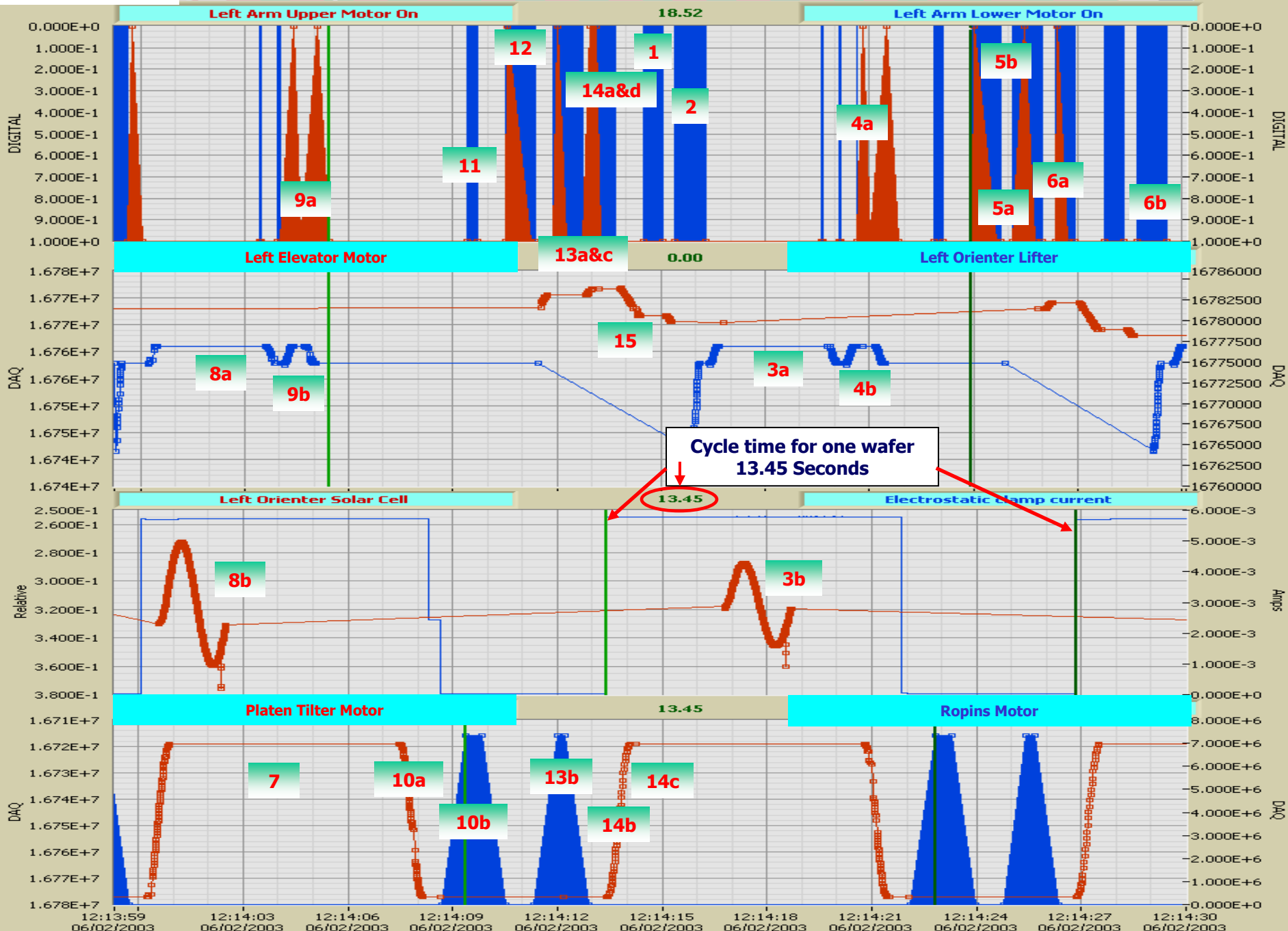

New 16 step Handling Sequence



Wafer Handler Processing Steps

1. The primary pick arm moves into the elevator and picks a wafer from the cassette.
2. The primary arm deposits the wafer on the pedestal in the low position.
3. The orienter pedestal lifts and removes the wafer in the low position, orients and centers the wafer, and moves to the new higher pedestal position.

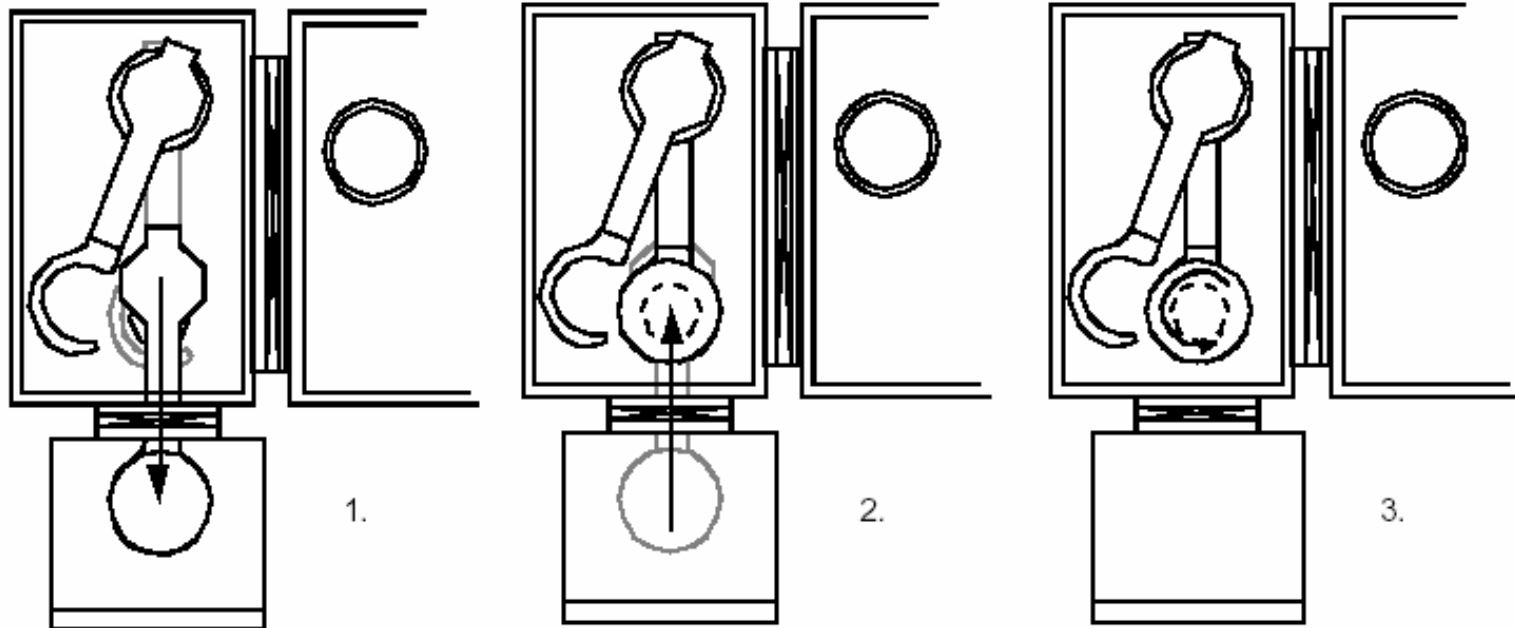

Handling Sequence



4. The secondary pick removes the wafer from the orienter pedestal in the new higher position. The orienter pedestal lowers to a position below both picks.
5. The secondary arm rotates into the target chamber and deposits the wafer onto the platen and simultaneously the primary arm moves into the elevator to get another wafer.

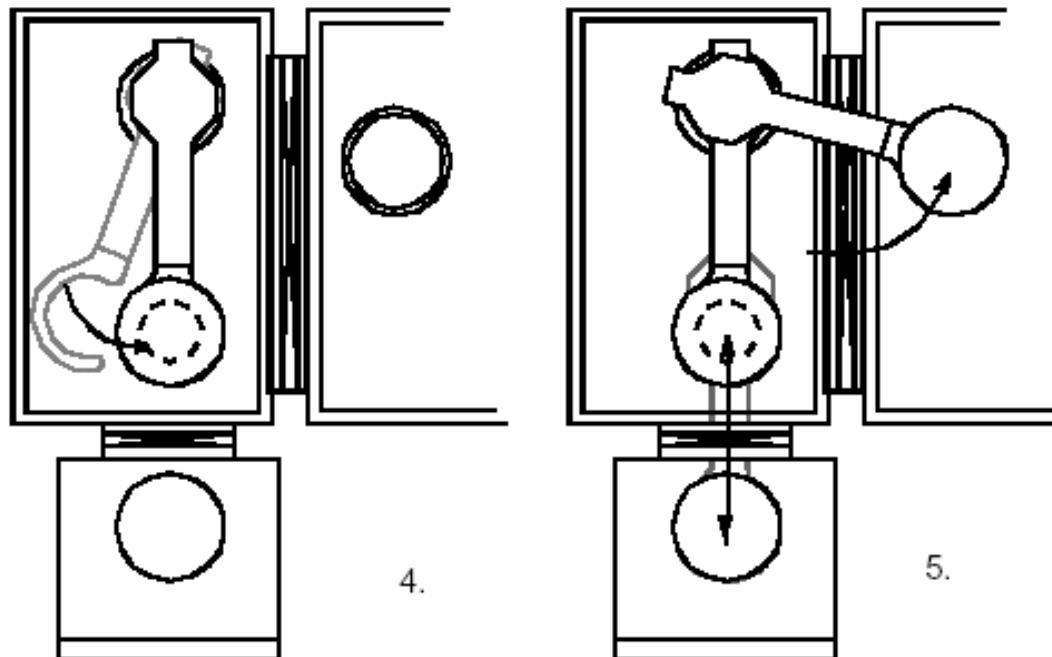

Handling Sequence



6. The secondary arm rotates to the idle position and the primary arm moves the wafer to the orienter pedestal.
7. The platen rotates and wafer implantation begins.
8. The orienter pedestal lifts and removes the wafer in the low position, orients and centers the wafer, and moves to the new higher pedestal position while the wafer is implanted.
9. The secondary pick removes the wafer from the orienter pedestal in the new higher position. The orienter pedestal lowers to a position below both picks.

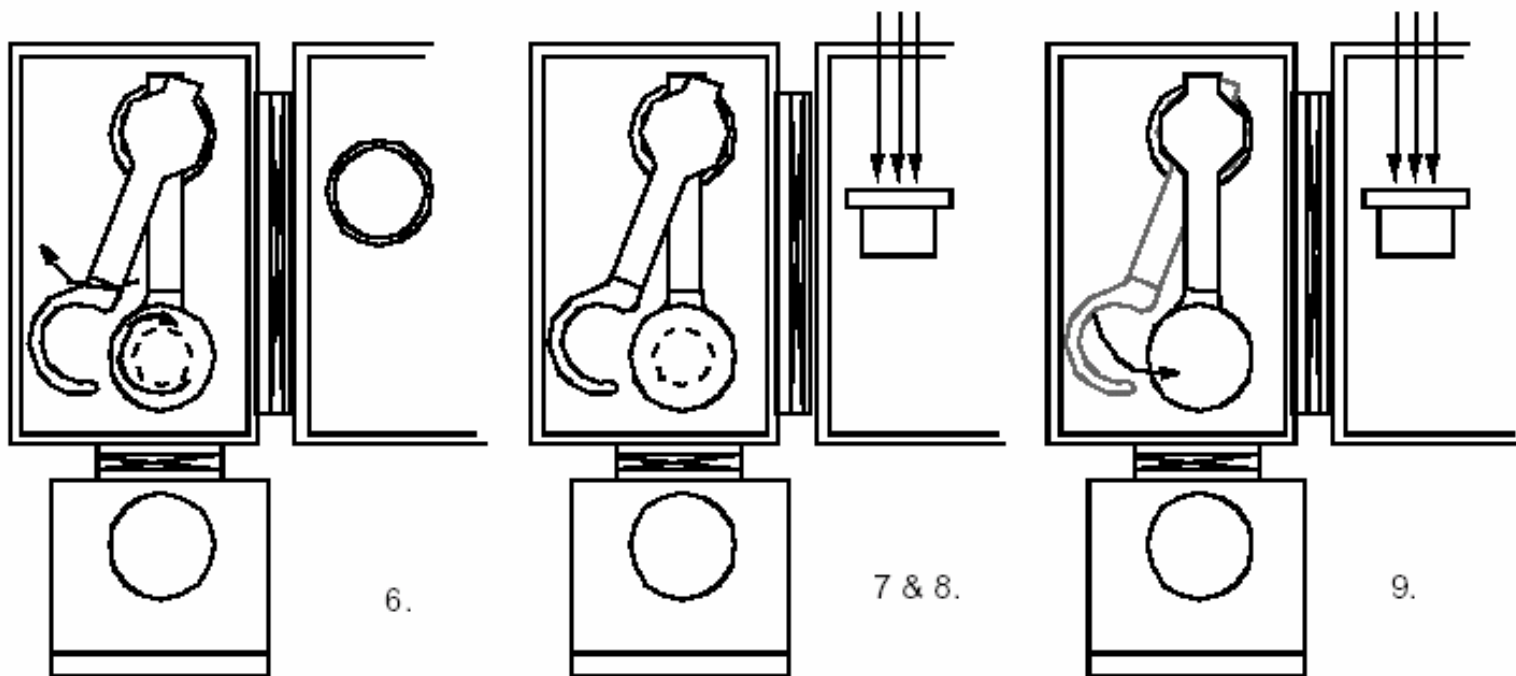

Handling Sequence



13. The secondary arm rotates to the platen, the platen pins lift and remove the wafer from the secondary arm, the primary arm moves into the elevator to deposit the implanted wafer.
14. The secondary arm rotates out of the target chamber to the idle position, the platen rotates to the implant position, the implant begins, and the primary pick arm moves out of the elevator without a wafer.

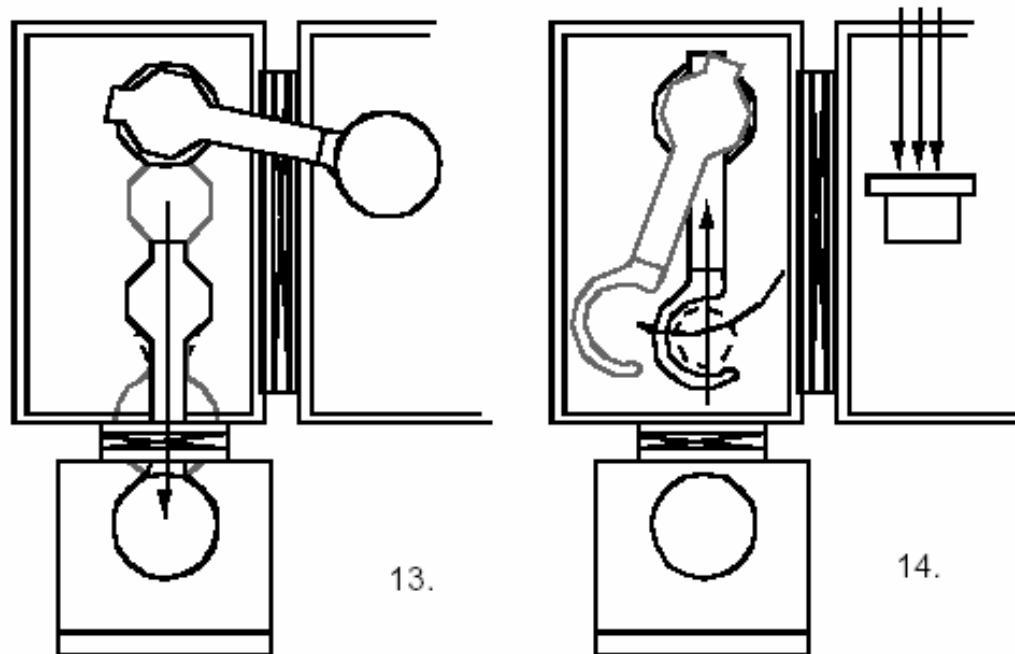

15. The elevator moves down to the next wafer slot.
16. The process repeats from step 1 until all of the wafers in the batch are processed.